

The iVapps System – General information

The iVapps plug valve body, or PORTAL, houses the stainless steel VALVE or SMART Cartridges. Manufactured with flanges according to ASME B16.10., the PORTAL is available in two materials: Ductile Iron with a 350 microns WRAS approved epoxy coating or Stainless Steel. The obturator is WRAS approved rubber plug, operated by a non-rising stem.

VALVE cartridge

The VALVE cartridge operates by inserting a robust EPDM plug into a fluid line to form a watertight seal to stop the flow. Once retracted the flow may continue. The iVapps VALVE cartridge creates a control or isolation point in a pipeline system.

The iVapps VALVE cartridge can be easily swapped with the iVapps SMART cartridge to form the above-mentioned control/isolation point when required.

The VALVE Cartridge is also available in a non-pressured version. Contact iVapps for more information.

Benefits

- Ease of installation – under 30 minutes.
- Once the iVapps PORTAL is in place, no digging is required to install the VALVE cartridge if the PORTAL is accessed via manhole.
- Available in the two most common UK pipe diameters.

Principal of Operation

The iVapps PORTAL is installed in the pipeline. For isolation purposes, the VALVE cartridge is fitted inside the PORTAL which has a moulded EPDM Plug to cut off the flow. This type of assembly acts as a standard plug valve.

Specifications

General Description

VALVE Cartridge

Application

Water pipelines used with a range of industries and applications

Physical

1. Model

P100, P150

2. Sizes

4" (100 mm), 6" (150mm)

3. Materials

Stainless Steel (UNS S21600 / Grade 316)

4. O Rings Seals

EPDM Plug

EPDM



Temperature
Nominal Pressure
Environment
After Sales Support
Warranty
Testing Standards

0°C to 50°C / 32°F to 122°F
0~ 16 bars / PN16
Can be installed in manholes or buried in the ground.
Visit www.ivappstech.com
1 year
API 598 and EN12266-1



Standard Assembly of DN100 VALVE Cartridge

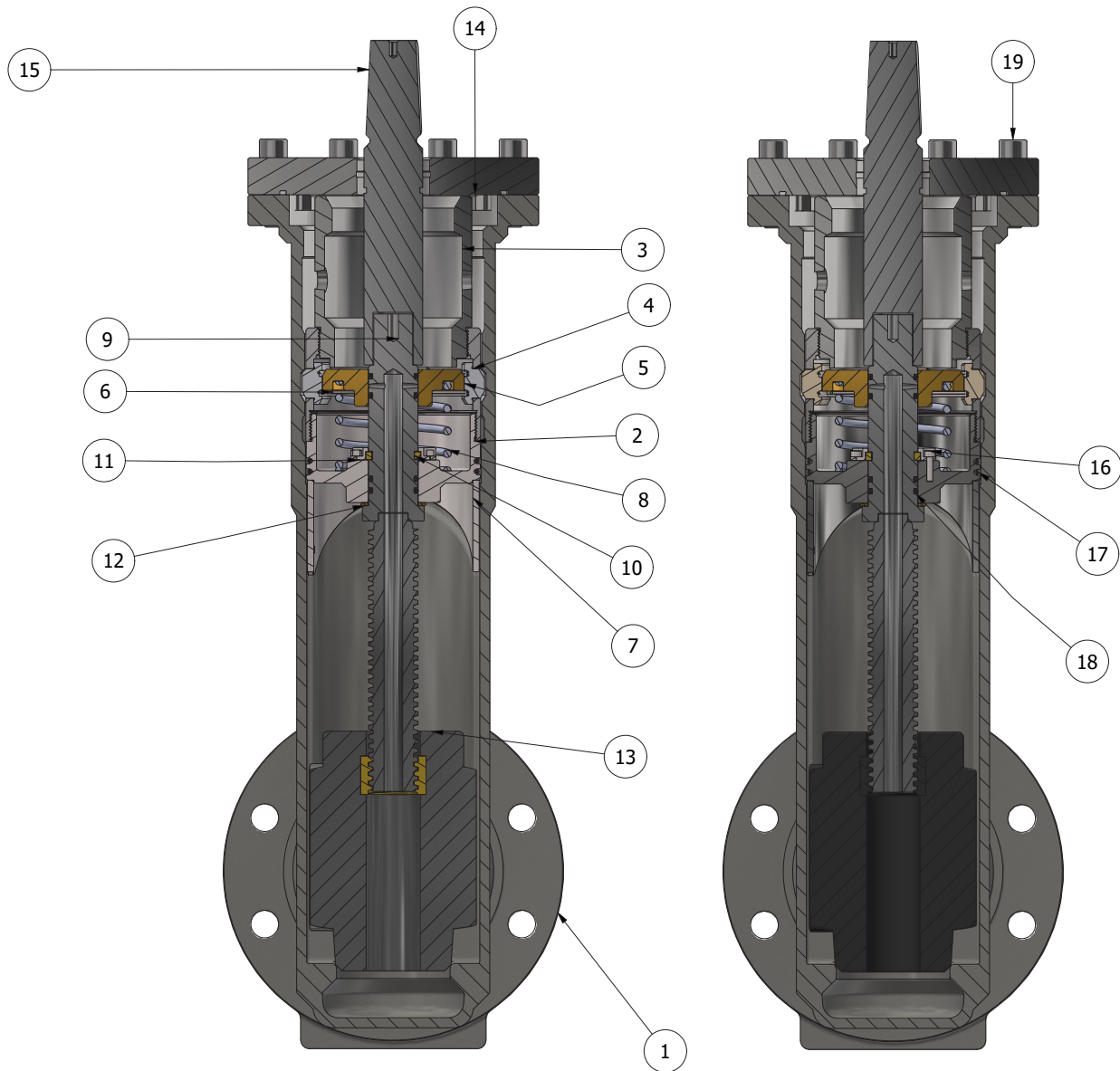

Component List

ITEM NO	PART DESCRIPTION	MATERIAL	QTY
1	PORTAL V22	EN-GJS-600-3	1
2	LOCK BODY	UNS S31600	1
3	FISHING NECK	UNS S31600	1
4	LOCK DOG	PEEK	4
5	SPRING LOCK DOG	UNS S31600	2

Component List cont.

6	COLLAR LOCK	BRASS	1
7	SEAL HOUSING [WELDED]	UNS S31600	1
8	SPRING COLLAR	UNS S31600	1
9	STEM WELD ASSY	UNS S31600	1
10	SPLIT RING	BRASS	1
11	COLLAR SPLIT RING	UNS S31600	1
12	BEARING STEM	BRASS	1
13	PLUG RUBBER [MOLDED]	EPDM	1
14	P LID	HDPE	1
15	P STEM CAP	6061 T6 HARD ANODISED	1
16	M5 X 12	A4	4
17	O-RING	EPDM	4
18	O-RING	EPDM	2
19	M12 X 35	A4	8

Sizes

REFERENCE	HEIGHT (MM)	WIDTH (MM)	DEPTH (MM)	WEIGHT (KG)
P100	502	113	113	7.81
P100	704	159	159	17.56